

## TOOLBASE Control AR-19 600 Professional

With its maximum payload of 600 kg, the TOOLBASE Control AR-19 600 was specially developed for the provision of cutting tools.

Three fixed drum versions exist, as well as the option of one-time configuring the drum to meet individual customer requirements, opening up almost unlimited application possibilities for industrial use. A maximum of 740 (standard) to 1,140 (special version) compartments on 19 levels are possible. Supported by the CORE software and a sliding door, only the previously selected item is made available to the user. In this way, tools are available close to use at all times.

The TOOLBASE Control AR-19 600 is also ideally suited for the individual dispensing of C-articles.

Standard color: RAL 7012 basalt gray matt



Technical data:	
Depth	1,025 mm
Width	985 mm
Height	1,980 mm
Withdrawal	Individual sampling, automatic control
Number of compartments	560 – 740 compartments (depending on configuration)
Tare weight // Payload	695 kg // Up to max. 600 kg (depending on configuration)

**TOOLBASE AR-19 600 Professional**

Drum design:

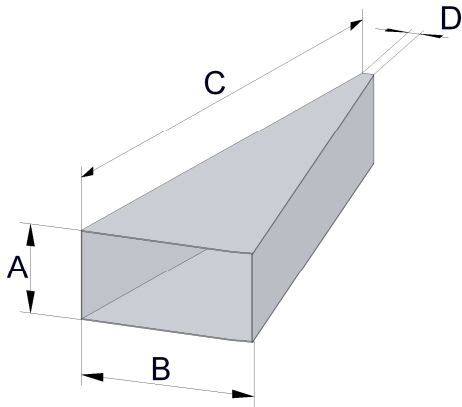

**TYP-1**

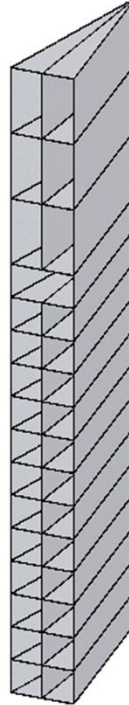

**TYP-2**

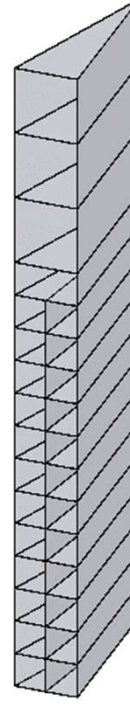

**TYP-3**

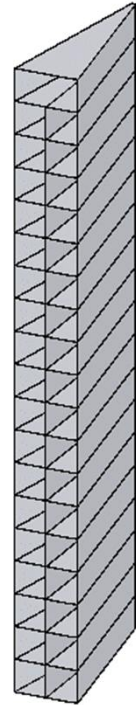

Compartment size (*)	Comp. per level	A (mm)	B (mm)	C (mm)	D (mm)	Max. load per comp. (kg)
2	40	80	68	316	32	3
3	20	80	136	316	51	3
5	40	160	68	316	32	3
6	20	160	136	316	51	3

(\*) Only one compartment size is possible per level

Variantes	TYP-1	TYP-2	TYP-3
<b>Total number of comp. (**)</b>	<b>620</b>	<b>560</b>	<b>740</b>
Number of levels	16	16	19
Comp. size 2	480	480	720
Comp. size 3	20	20	20
Comp. size 5	120	-	-
Comp. size 6	-	60	-

(\*\*) Subsequent adjustment of the drum configuration by the customer possible to a limited extent after consultation